

**BA 102 - BA 202 - BA 302 - BA 402 -
BA 452 - BA 552 - BA 602**

**Clamshell grab
earth moving or rehandling**

- 1 Rotation 360°.
- 2 1 horizontal cylinder (BA102/BA202).
- 3 Earth moving or rehandling.
- 4 Hydraulic rotation 360° for accurate positioning. Rotator fitted with ball bearing to avoid wearing. Protection of hoses on rotator.
- 5 Cast iron frame.
- 6 Protection of piston rod.
- 7 Cast iron shells link.
- 8 Quick coupling system for shells. The frame remains on the excavator. Only 3 pins to remove.

Optional : ejectors

BA 102 - BA 202

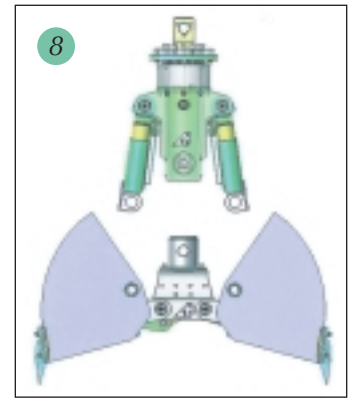
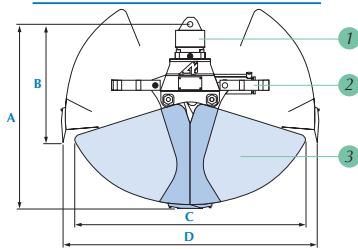

BA 302 - BA 402 - BA 452 - BA 552 - BA 602

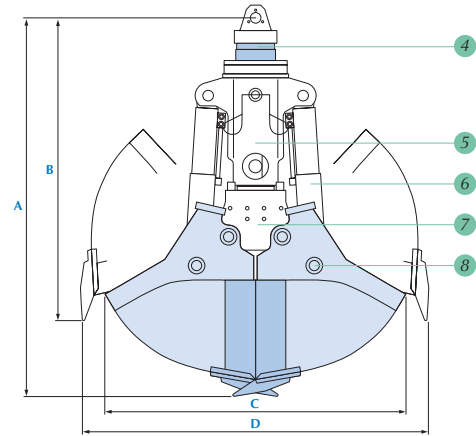

	t	kg	A	B	C	D	l	mm	bar	l/mn	bar	l/mn	t	tm
			mm	mm	mm	mm								
BA 102	4	260	1095	700	1360	1535	190	400	320	25/50	320	3/5	5/7	8/15
		270					220	450						
		275					240	500						
		290					290	600						
		310					340	700						
BA 202	6	300	1180	785	1360	1535	190	400	320	25/50	320	7/10	8/10	16/24
		310					220	450						
		315					240	500						
		330					290	600						
		350					340	700						
BA 302 T	6	490	1770	1550	1460	1620	145	300	320	40/75	320	7/10	11/15	
		490					200	400						
		520					250	500						
		545					305	600						
		575					360	700						
BA 302 R	6	610	1690	1435	1460	1520	525	1000	320	40/75	320	7/10	16/19	
	BA 402 T	10					555	145						300
							555	200						400
							585	250						500
							610	305						600
	640	360	700											
	670	415	800											
	700	470	900											
BA 402 R	10	675	1690	1310	1460	1520	525	1000	350	40/75	200	13/18	18/22	
	BA 452 T	10					720	175						300
							695	240						400
							730	305						500
							755	370						600
	830	435	700											
	855	500	800											
	890	560	900											
	920	625	1000											
BA 452 R	9	1000	1905	1435	1710	1790	1000	1200	350	85/165	250	18/27	23/30	
	BA 552 T	15					1150	350						400
							1240	550						600
							1320	750						800
							1470	950						1000
	1550	1150	1200											
BA 552 R	15	1680	2310	1670	1930	2060	1450	1500	350	85/165	250	20/30	27/40	
	BA 602 T	20					1900	1970						1600
							1945	2100						1700
							1990	2350						1900
							2125	2470						2000
	2165	2600	2100											
BA 602 R	20	2125	2450	1680	2080	2360	2350	1900	350	85/165	250	20/30	27/40	
		2165					2470	2000						
	2215	2600	2100											

Kg : Weight mentioned without suspension

Your dealer



14, avenue de l'Industrie
F-08013 CHARLEVILLE-MÉZIÈRES Cedex
Tél. : (33) 03.24.33.64.30
Fax : (33) 03.24.33.64.32
E-mail : arden-equipment@arden-equipment.com
www.arden-equipment.fr