

AB 152 - AB 212 - AB 282 - AB 352 - AB 502 AB 852 - AB 1052 - AB 1352 - AB 1852 AB 2452 - AB 2852 - AB 3552 - AB 4052

Breakers

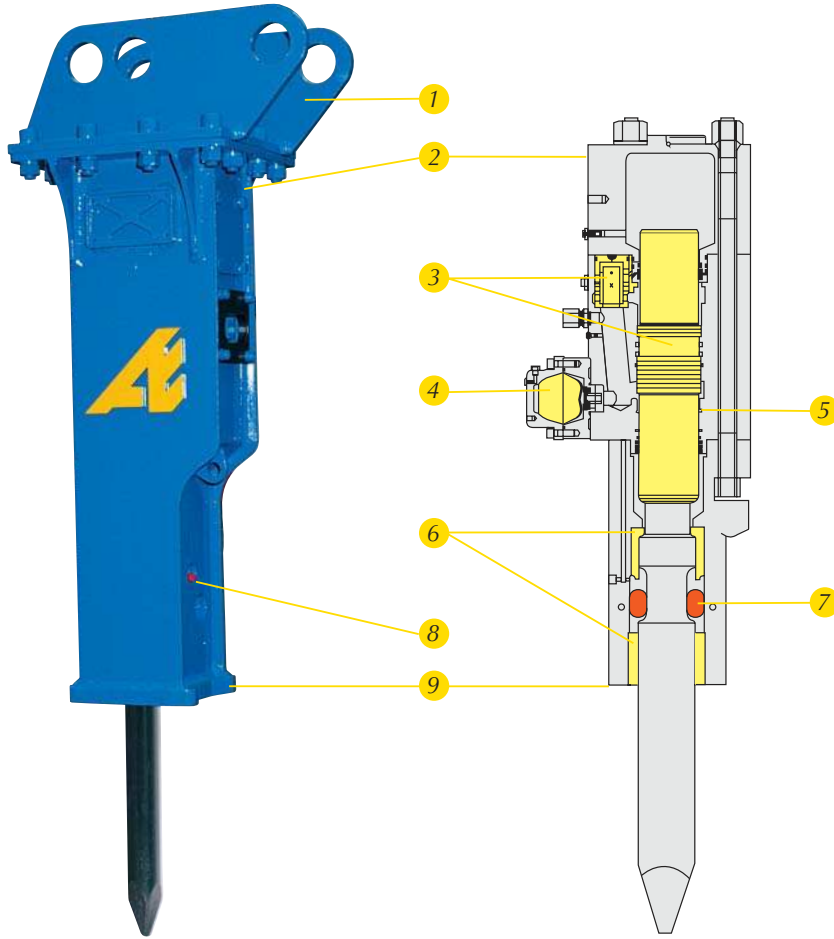

- 1 Top Plate for bolt on bracket.
- 2 Silenced absorbers.
- 3 Only 2 moving components : control valve and piston therefore low maintenance.
- 4 Nitrogen energy chamber absorbing vibrations.
- 5 Idle stroke protection.
- 6 Twin bushes chisel guide.
- 7 Quick change retaining pins.
- 8 Easy greasing system.
- 9 Reinforced lower part of body.

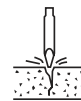
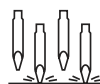
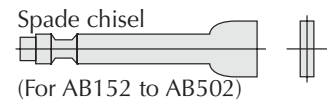
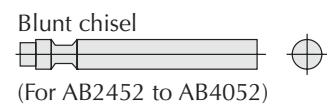
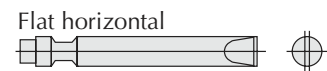
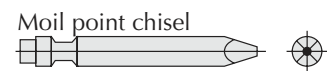

		≈ kg	Litres/mn	bar	bar	Nb/mn	joule	mm	t	t
AB 152	-	145	20/30	90/110	180	450/800	343	57	1,3/3	-
AB 212	-	180	26/40	90/130	180	450/800	392	57	2,5/4,5	-
AB 282	X	250	25/45	90/130	180	550/1100	696	70	3/6	4/7
AB 352	X	310	30/55	90/130	220	380/1000	736	70	4/8	5/10
AB 502	X	480	40/65	140/160	220	400/1100	1177	80	6/10	6/12
AB 852	X	740	65/95	140/160	300	350/900	2158	95	10/14	-
AB 1052	X	960	80/110	140/160	300	350/900	2518	105	12/18	-
AB 1352	X	1360	100/135	160/190	300	320/800	3880	125	16/24	-
AB 1852	X	1800	120/150	160/190	300	340/800	5350	135	22/30	-
AB 2452	X	2450	150/230	160/190	300	250/650	8750	150	25/36	-
AB 2852	X	2850	190/250	160/190	300	230/600	10897	155	28/42	-
AB 3552	X	3550	200/260	160/190	300	230/600	12250	165	34/50	-
AB 4052	X	4000	210/280	160/190	300	230/550	15240	175	40/60	-

Weight without top plate.